

POWERTEC

STRENGTH

L-PL

Manual

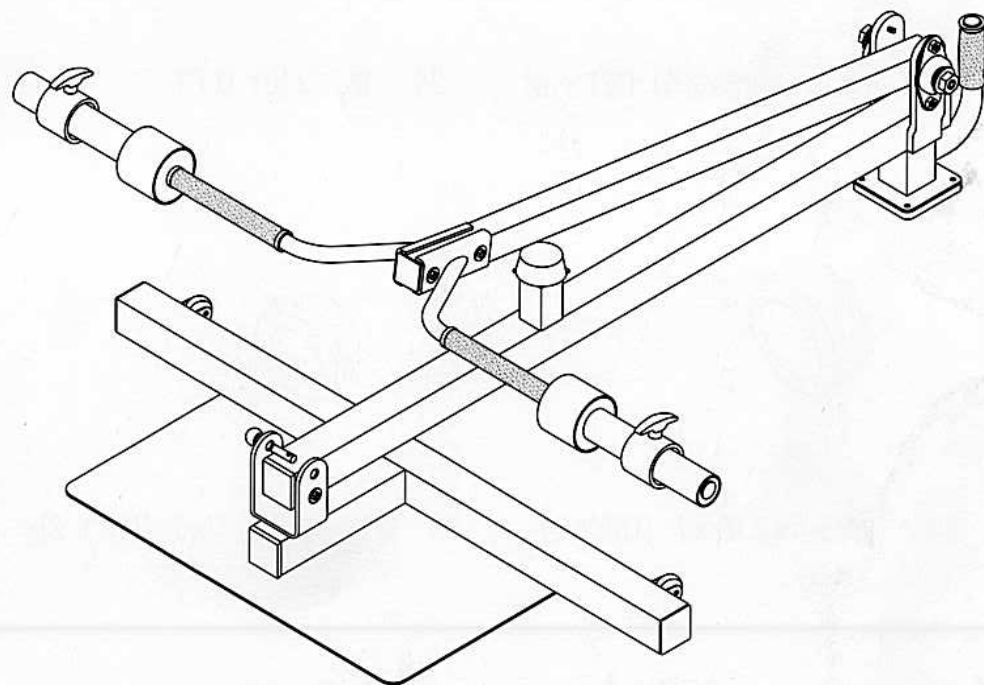

LEVERAGE POWER LEVER

HARDWARE LIST

POWERTEC

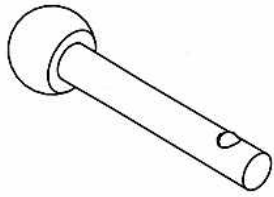

11 $\phi 12.7 \times 100$ (QTY:1)

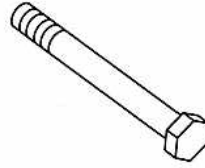

17 1/2"x2-5/8" (QTY:1)

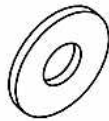

20 $\phi 14 \times \phi 28 \times 2.0$ (QTY:6)

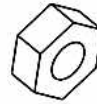

21 1/2"x16 (QTY: 3)

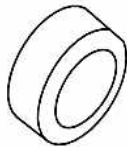

33 $\phi 25.4 \times 2.0$ (QTY:2)

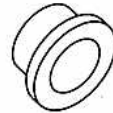

07 $\phi 20.1 \times \phi 25.4 \times 3$ (QTY:2)

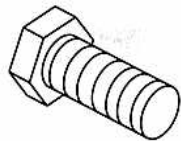

18 1/2"x1/2" QTY: 2

L-PL

LEVERAGE POWER LEVER

PART LIST

POWERTEC

Part Description	QTY	Part Description	QTY
1 Lower Lever Arm	1	18 1/2" x 1/2" Hex Bolt	6 (*4)
2 Footplate Frame	1	19 1/2" x 1" Pocket Hex Bolt	2
3 Upper Lever Arm	1	20 1/2" Washer	12 (*6)
4 Handle Arm	2	21 1/2" Nylon Nut	5 (*2)
5 Weight Adaptor	2	22 Bearing Shroud	2
6 Collar	2	23 Spacer	4
7 Metal Bushing	2	24 Transport Wheel	2
8 Rubber Bumper	1	25 5/16" x 1-1/2" Half Thread Hex Bolt	2
9 Hand Grip	2	26 3/8" x 1" Hex Bolt	1
10 PVC Sleeve	2	27 3/8" Washer	2
11 Ball Head Lock Pin	1	28 5/16" Nylon Nut	2
12 Square Inner Plug	5	29 Hand Grip	1
13 Square Inner Plug	2	30 Rubber Bumper	1
14 Round Inner Plug	2	31 M5 Screw	4
15 Steel Axis Tube	1	32 5/16" Washer	1
16 Steel Axis Tube	1	33 Spacer	2
17 1/2" x 2-5/8" Half Thread Hex Bolt	1	34 Nameplate	1

* Indicates parts which have been pre-installed or pre-assembled

L-PL

LEVERAGE POWER LEVER

EXPLODED DIAGRAM

POWERTEC

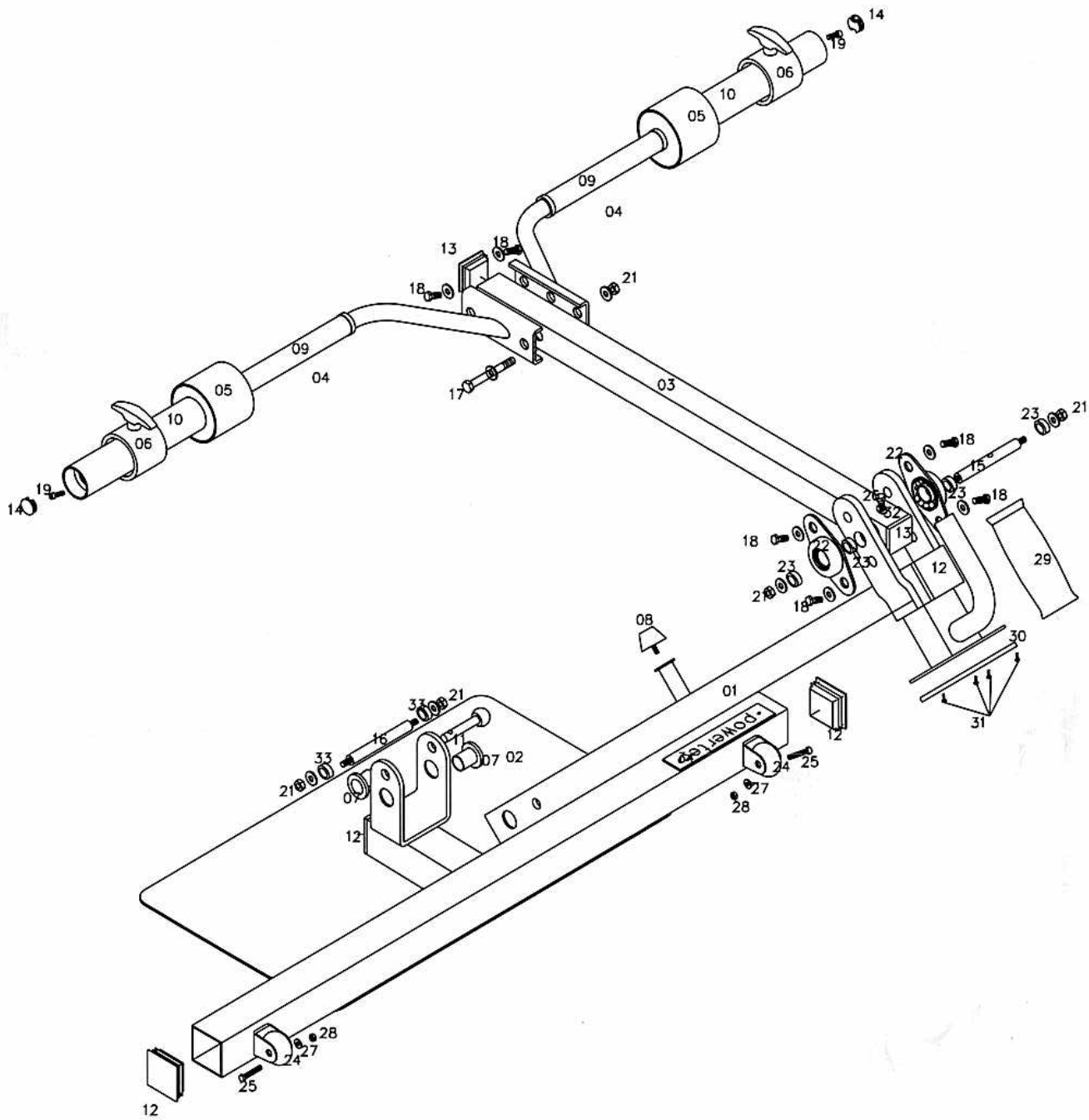

L-PL

LEVERAGE POWER LEVER

ASSEMBLY ONE

NOTE: Always insert all bolts through holes prior to tightening due to precision fit

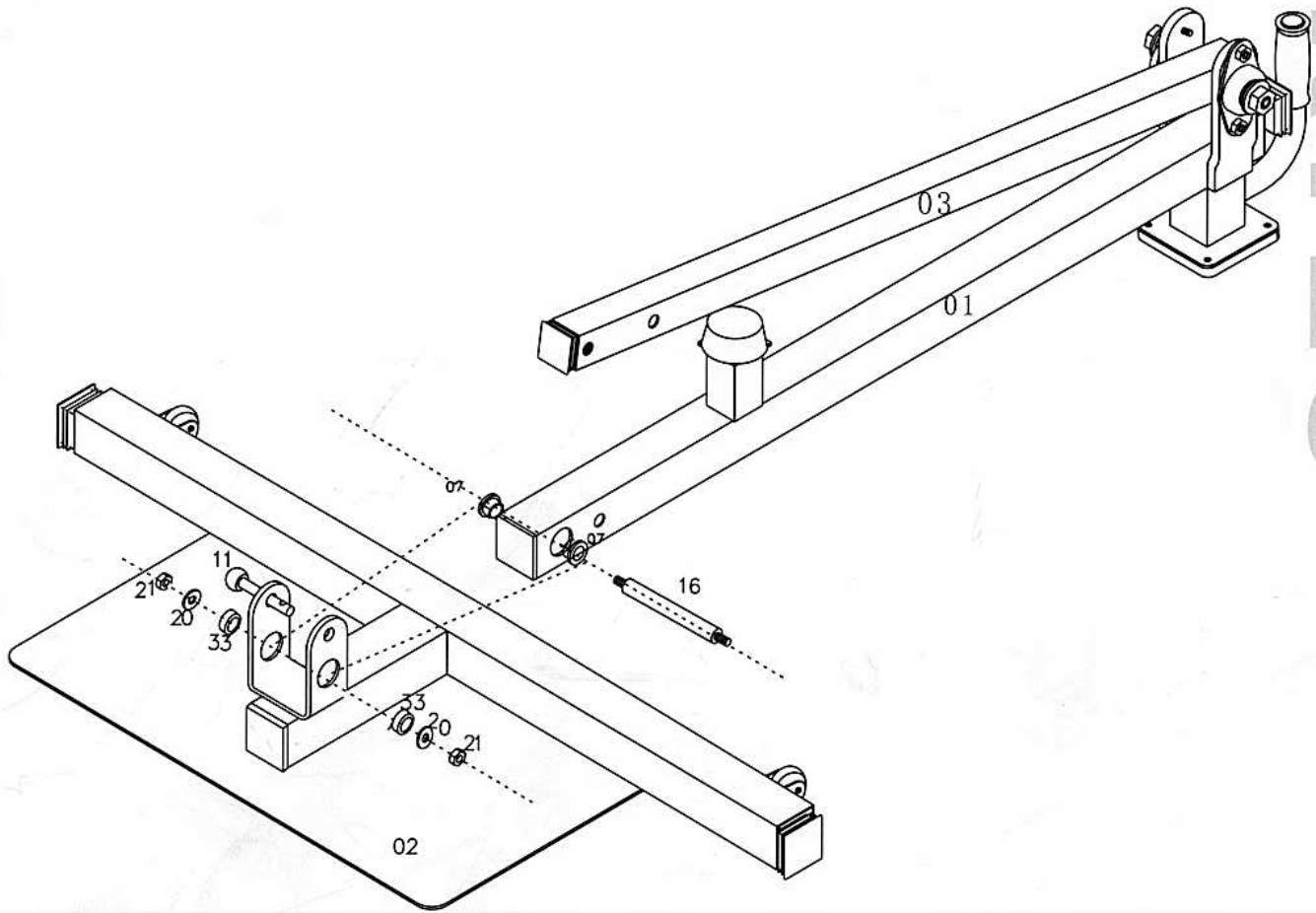

POWERTEC

L-PL

LEVERAGE POWER LEVER

ASSEMBLY THREE

POWERTEC

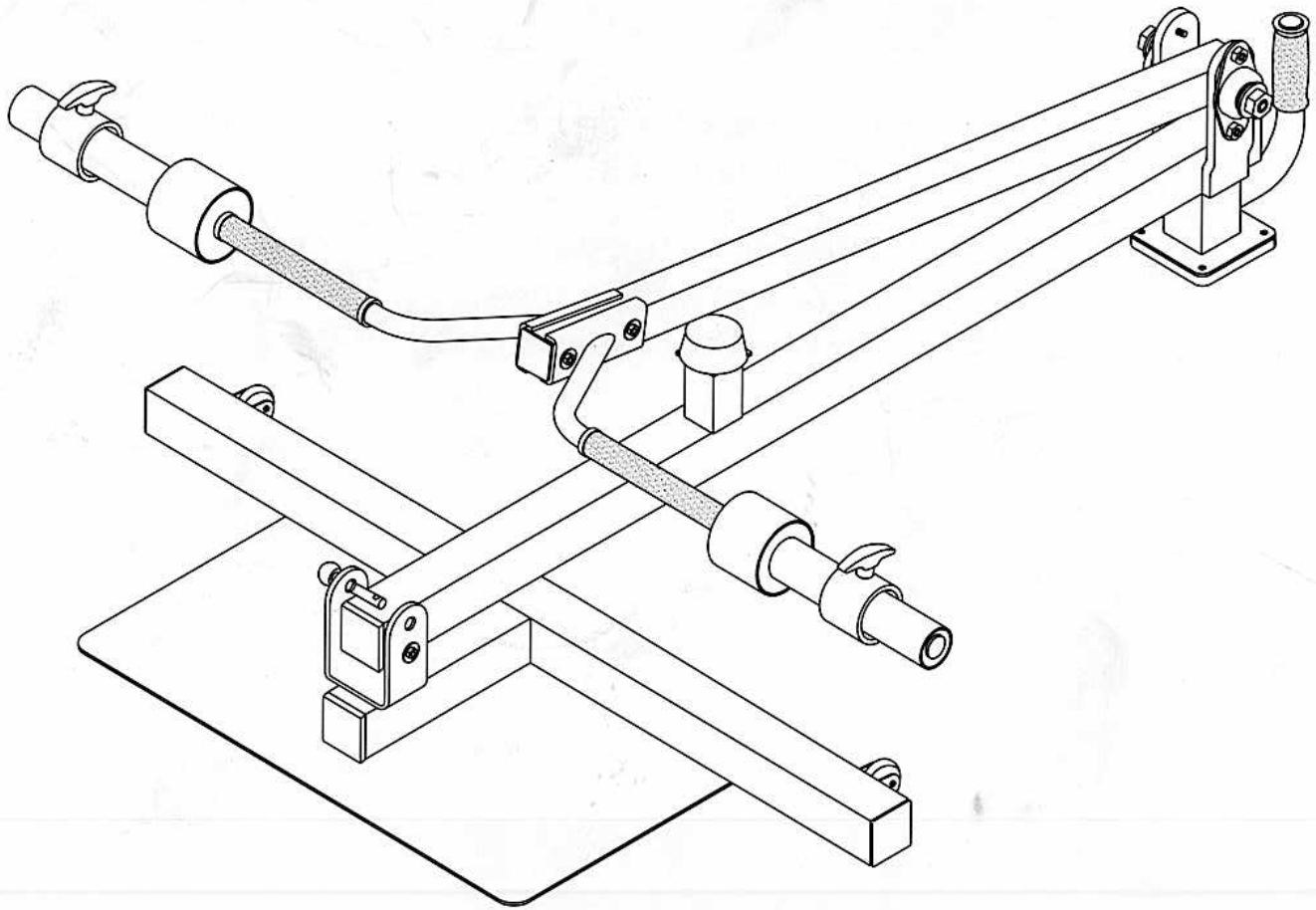

Tighten All Bolts before using this equipment !

L-PL

LEVERAGE POWER LEVER

POWERTEC IS NOT LIABLE IF THE TRAINER SHOULD INJURE THEMSELVES WHILE USING **POWERTEC** EQUIPMENT OR WHILE PERFORMING THE TRAINING ROUTINE

POWERTEC

STRENGTH

Powertec, inc.

601W. Harford St. Milford.

PA 18337

PHONE: (570) 296-5005

FAX: (570) 296-5009

www.powertecfitness.com

LIFETIME WARRANTY