

 **POWERTEC®**

WB-DMA16

Manual

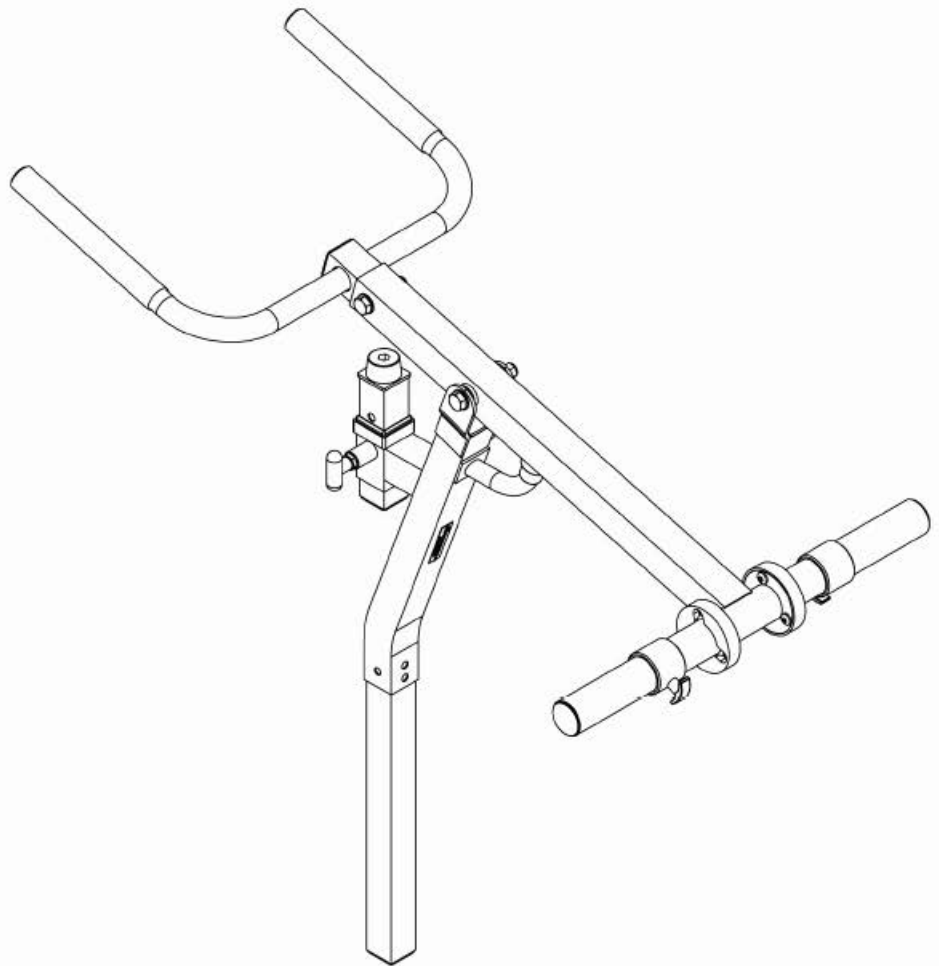

WORKBENCH DIP ACCESSORY

Thank you for purchasing your new Powertec equipment.
 To maximize the use of this Equipment, please take a moment to study, understand and familiarize with the assembly instructions and follow the sequence of steps as provided in the manual.

Because of our products unique features, this manual was created to provide you with information on how to assemble and properly maintain your equipment.

Table of Contents

Introduction and Weight Capacities..... 2
 Safety Instructions, Warnings and Cautions 3
 Maintenance Tips..... 4
 Tools Required for Assembly..... 5
 Hardware List..... 6
 Part List..... 7
 Exploded Diagram..... 8
 Assembly Steps..... 9
 Warranty Certificate..... 10
 Warranty Registration Card..... 11

**WB-DMA16
 WORKBENCH DIP ACCESSORY**

Weight Capacities

Maximum Load: 200 Lbs.

Featured Exercises

Machine Dips Tricep Pushdowns

Recommended Accessories

- | | | | |
|-----------------|-------------------------------|-----------------|-------------------------------|
| WB-LTA16 | Lat Tower Accessory | WB-LLA16 | Leg Lift Accessory |
| WB-LPA16 | Leg Press Accessory | WB-ASR16 | Accessory Storage Rack |
| WB-CMA16 | Curl Machine Accessory | WB-PFA16 | Pec/Fly Accessory |

SAFETY INSTRUCTIONS, WARNINGS AND CAUTIONS



It is recommended that users of this equipment receive a thorough medical exam before commencing any exercise program. This is especially important if you have never Exercised and or are over the age of 35, are pregnant or suffer from any health issues.

Read All Warnings and Cautions on this Manual and on the Product

This product should only be used after a thorough review of the Owner's Manual.

Keep children away from the product when in use.

Set up and operate the product on a solid level surface.

Do not set up the product on loose rugs or uneven surfaces.

Make sure adequate space is available to exercise and move around the product.

Inspect product before and after each use, inspect for worn out or loose parts, repair or replace as needed.

This equipment meets industry safety standards for stability when used for the intended exercise. Do not allow straps, resistance bands or other means to be attached to the framework of this equipment to perform stretching or body weight exercises as it can result to equipment instability and lead to serious injuries.

Always choose a workout that best fits your needs, physical strength and flexibility Levels, know your limits and your product limits and train within them.

Always wear proper footwear with nonskid rubber soles such, running, walking or Cross training shoes that fit well and provide support.

Do not exercise bare foot or in socks.

Always use common sense when exercising.



MAINTENANCE



The safety and performance of this product can be maintained only if it is examined regularly for damage and normal wear. Examine the equipment before each use for damage and wear. Replace damaged and worn components immediately or put the equipment out of use until repaired.

Inspect Daily / Before Each Use!

Inspect system. Make sure it is in good condition and operates smoothly. If you find damage, **DO NOT USE**. Contact your authorized Powertec dealer or Powertec Customer Service Center for assistance.

Inspect Daily / After Each Use!

Clean system with a clean, dry cloth. Use a mild detergent or spray on upholstery. Do Not use cleansers containing enzymes.

Inspect Weekly!

Clean your system fully with a clean and ammonia based cleaner. Touch up any scratches with touch-up paint to prevent rust, if necessary.

Inspect Monthly!

Examine the frame for signs of cracking or permanent bending. Do not use the equipment if you see this. Contact Powertec Customer Service Immediately. If you have any questions on the correct use or maintenance of this equipment, call your authorized distributor or Powertec Customer Service at 800-250-6665

Our Customer Service Mission:

“Committed to Stronger Lives”

By providing friendly and understanding service.

Tools Required for Assembly

 POWERTEC®



M6 Allen Wrench



Wrenches
13 mm = 1/2"
19 mm = 3/4"
21 mm = 13/16"



8" Adjustable Wrench

HARDWARE LIST

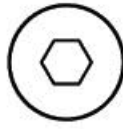
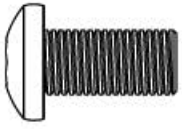

No.8 Hex Bolt 3/8" X 3/4"(GR8)

No.14 Nylon Nut 3/8"

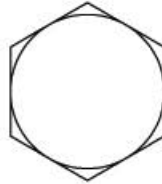
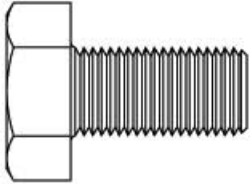

No.11 Hex Bolt 1/2" X 1"

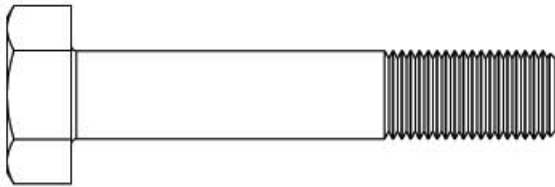

No.9 Hex Bolt 1/2" X 2 3/4"

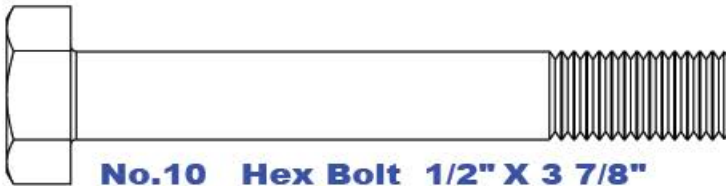

No.10 Hex Bolt 1/2" X 3 7/8"

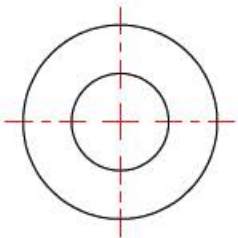

No.12 Washer 1/2"

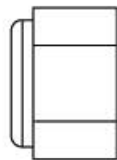

No.13 Nylon Nut 1/2"

WB-DMA16

WORKBENCH DIP ACCESSORY

PARTS LIST



Item#	Description	Qty
1	Upright	1
2	Weight Horn Tube	1
3	Handle Bar	1
4	Height Adjustment Tube	1
5	Weight Horns	2
6	Collars	2
7	Rubber Bumper	2
8	Round Head Bolt 3/8" x 3/4"	6
9	Hex Bolt 1/2" x 2 3/4"	1
10	Hex Bolt 1/2" x 3 7/8"	1
11	Hex Bolt 1/2" x 1"	1
12	Washer 1/2"	5
13	Nut 1/2"	2
14	Nut 3/8"	6

WB-DMA16

WORKBENCH DIP ACCESSORY

EXPLODED DIAGRAM

POWERTEC[®]

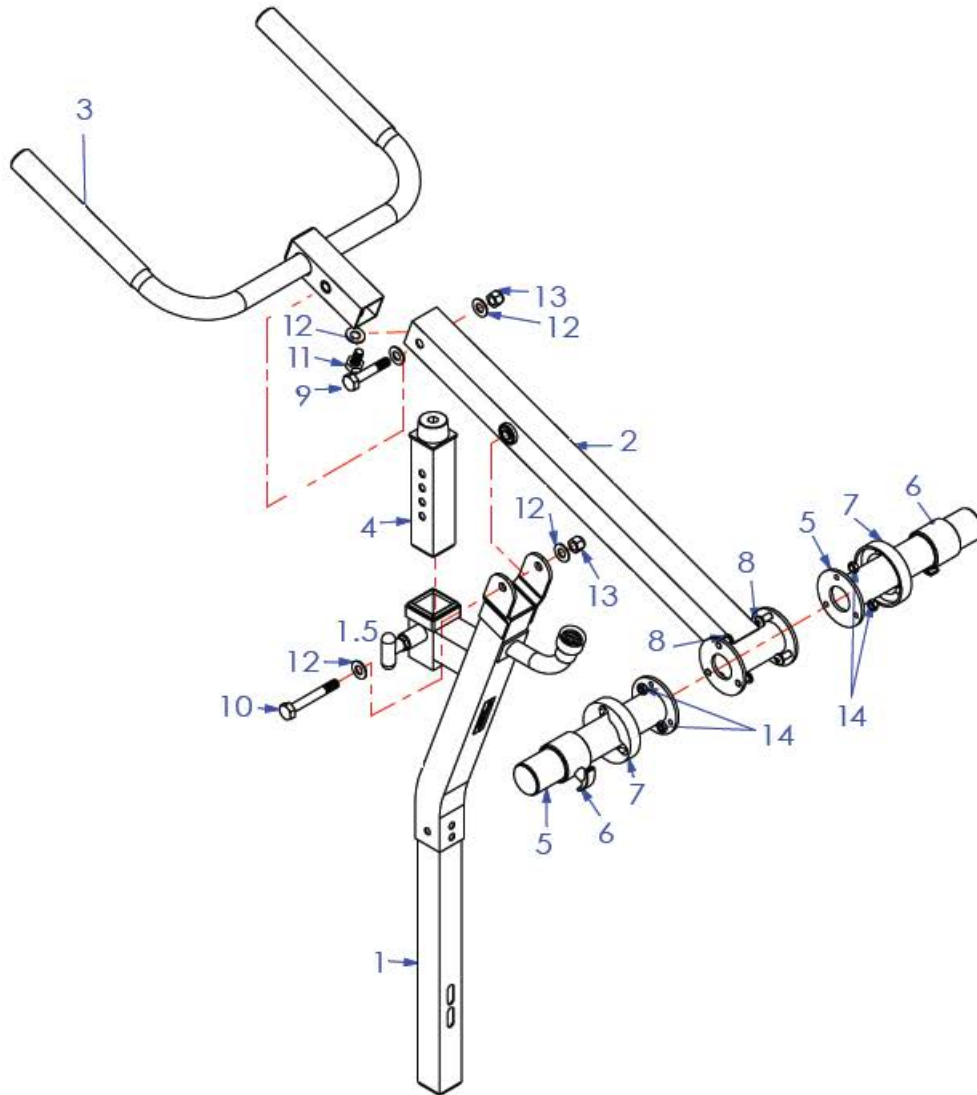

WB-DMA16

WORKBENCH DIP ACCESSORY

Assembly Instructions

POWERTEC[®]

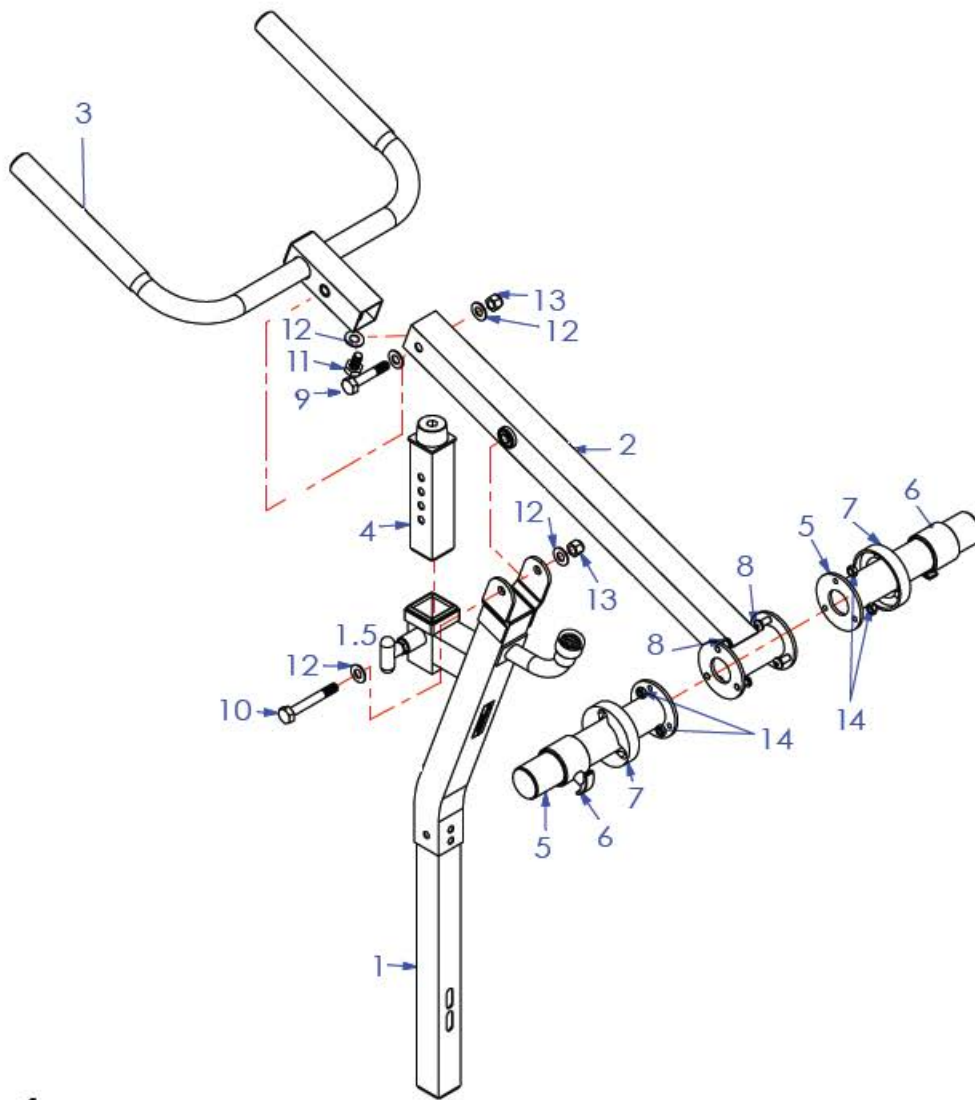

Step 1

Install Handle Bar Part No. 3 to Weight Horn Tube No. 2
Use Bolt No. 9, Washers No. 12 and Nut No. 13.
Insert Bolt No. 11 on the underside, include Washer No. 12
and fully tighten hardware.

Step 2

Install Weight Horns No. 5 on to Weight Horn Tube No. 2
Use Bolts No. 8 and Nuts No. 14
Proceed and Slide Rubber Bumpers No. 7 and Collars No. 6

Step 3

Attach Up-Right No. 1 and Handle Bar Assembly / Weight
Horn Tube No. 2 together using Bolt No. 10, Washers No. 12
and Nut No. 13 and Tighten Hardware.

Note:

Height of the Handle Bar Assembly can be adjusted as needed
by using the T Handle Pin, adjust height and lock into position.

WB-DMA16

WORKBENCH DIP ACCESSORY

WARRANTY

Serial No.

Thank you for purchasing one of Powertec's products.

Powertec warrants that the Product you have purchased is free from defects in materials and workmanship.

Powertec offers a Lifetime Warranty on Structural Frame.(Excludes Surface Finish).
5 year warranty on Moving Frames (Press Arms and other unspecified moving components).
Two year warranty on Components (Bearings, Locking Pins, Pulleys, Cables, Slide Rods).
One year warranty on Pads, Grips and other unspecified parts.

- All parts are shipped free of charge for first 90 days of date of purchase.
- Warranty is to original purchaser only (excluding dealer). Warranty is not Transferable in the event you sell the product.
- Warranty claims are subject to inspection and are voided if equipment shows Signs of abuse or alterations made other than the ones recommended by Powertec.
- Missing parts must be reported within 30 days from receipt of unit(s).
- Proof of purchase is required; your sales receipt must show date of purchase.
- For more information on the warranty or to obtain warranty service, please contact The appropriate Powertec Customer Service Department in the USA or Europe.

Powertec Inc. USA
2100 E. Artesia Boulevard
Long Beach, CA. 90805 – USA

Powertec Europe
6, Rue de l'Europe
68500 Bergholtz - France

Phone: (800) 250-6665
E-mail: service@powertecfitness.com

Phone: + 33 (0) 3 89 62 56 30
E-mail: contact@powertec-europe.fr

Thank you for giving us the opportunity to fulfill your strength and fitness needs.

POWERTEC® Customer Warranty Information Sheet

Last Name: _____ First Name: _____

Company: _____

Street Address: _____

City: _____ State: _____ Zip Code: _____

Daytime Telephone No: _____ Alternate Telephone No. _____

E-Mail: _____ Date of Purchase: _____ Purchase Price: _____

Dealer Name and Address: _____

Model Name & Code: _____ Optional: Male / Female: _____ Age: _____ Occupation: _____

POWERTEC IS NOT LIABLE IF THE TRAINER SHOULD INJURE THEMSELVES WHILE USING POWERTEC EQUIPMENT OR WHILE PERFORMING THE TRAINING ROUTINE



COMMITTED TO STRONGER LIVES[®]

POWERTEC INC.
2100 East Artesia Boulevard
Long Beach, CA. 90805 - USA

Phone: (800) 250-6665
Fax: (714) 908-0493
service@powertecfitness.com
www.powertecfitness.com

POWERTEC EUROPE
6, Rue de l'Europe
68500 BERGHOLTZ - France

Phone: + 33 (0) 3 89 625 630
Fax: + 33 (0) 3 89 625 631
E-mail: contact@powertec-europe.fr

Return Warranty Registration Card to Appropriate Powertec Address:



Place
Stamp
Here



